



**ATLAS  
SEALS**

THE PINNACLE OF  
SEALING PERFORMANCE



# LOCKSTEP™

ROTARY SEAL FOR SEVERE APPLICATIONS

PATENTS PENDING

INDUSTRIAL  
ENERGY  
ENVIRONMENT  
AERONAUTICS  
CHEMICAL  
MEDICAL



## THE ATLAS DIFFERENCE

Atlas Seals provides solutions and stability when it seems that there are none available. The Atlas Seal difference is intuition. Our intuition comes from three generations and over 100 years of combined experience in the business of providing sealing solutions. Focus was a founding principle of Atlas Seals by specializing only in engineering plastics seals for tough applications. We conduct business in a personal nature, building lasting relationships and providing each customer a tailored sealing solution designed for their specific application.

## OUR METHODOLOGY

From the beginning, Atlas Seals embraced a single philosophy, "Performance lives in simplicity." The principles of sealing dynamics are well understood. We help our customers succeed through a better understanding of their unique application and needs.

Atlas Seals affords you peace of mind and confidence in knowing your products will perform exceptionally well for their intended service life. Atlas Seals should be your first-choice partner for developing the products you are passionate about.

**WHAT IS LOCKSTEP™?** 1

**EXAMPLE LOCKSTEP™ DESIGNS** 2

**LOCKSTEP™ IN PTFE** 4

**ALTERNATIVE TO METAL CASE LIP SEALS** 5

**PRESSURE & VELOCITY CAPABILITIES** 6



**ATLAS SEALS**  
THE PINNACLE OF SEALING PERFORMANCE

# WHAT IS LOCKSTEP™?

**Robust retention system for seals. Easy install.**

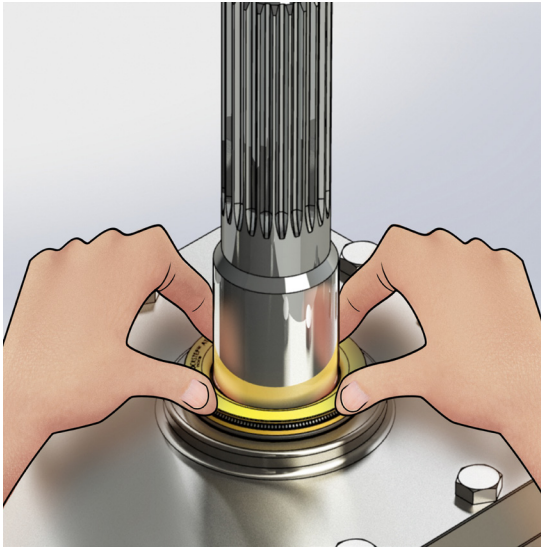

Easy push into housing, usually by hand force only.

No snap rings nor retaining hardware needed.

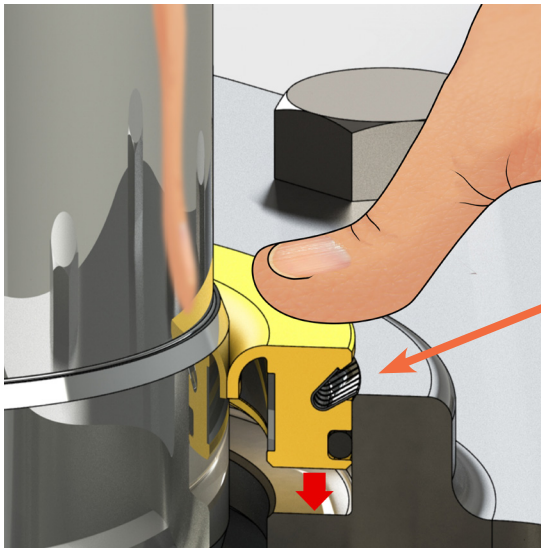

Patented angled locking barb\* deforms on install then camlocks to housing material.

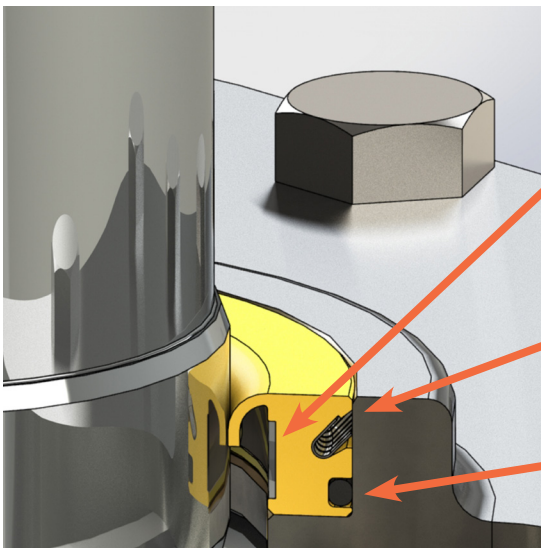

Formed metal support ring assures seal won't resize or become loose in housing.

The metal barb locks in place. It cannot slip out nor rotate.

O-ring provides robust static sealing in housing.

\* The locking barb and support ring are formed from stock materials on demand. Eliminating tooling allows rapid prototypes and affordable low volume orders.

WHAT IS LOCKSTEP™?

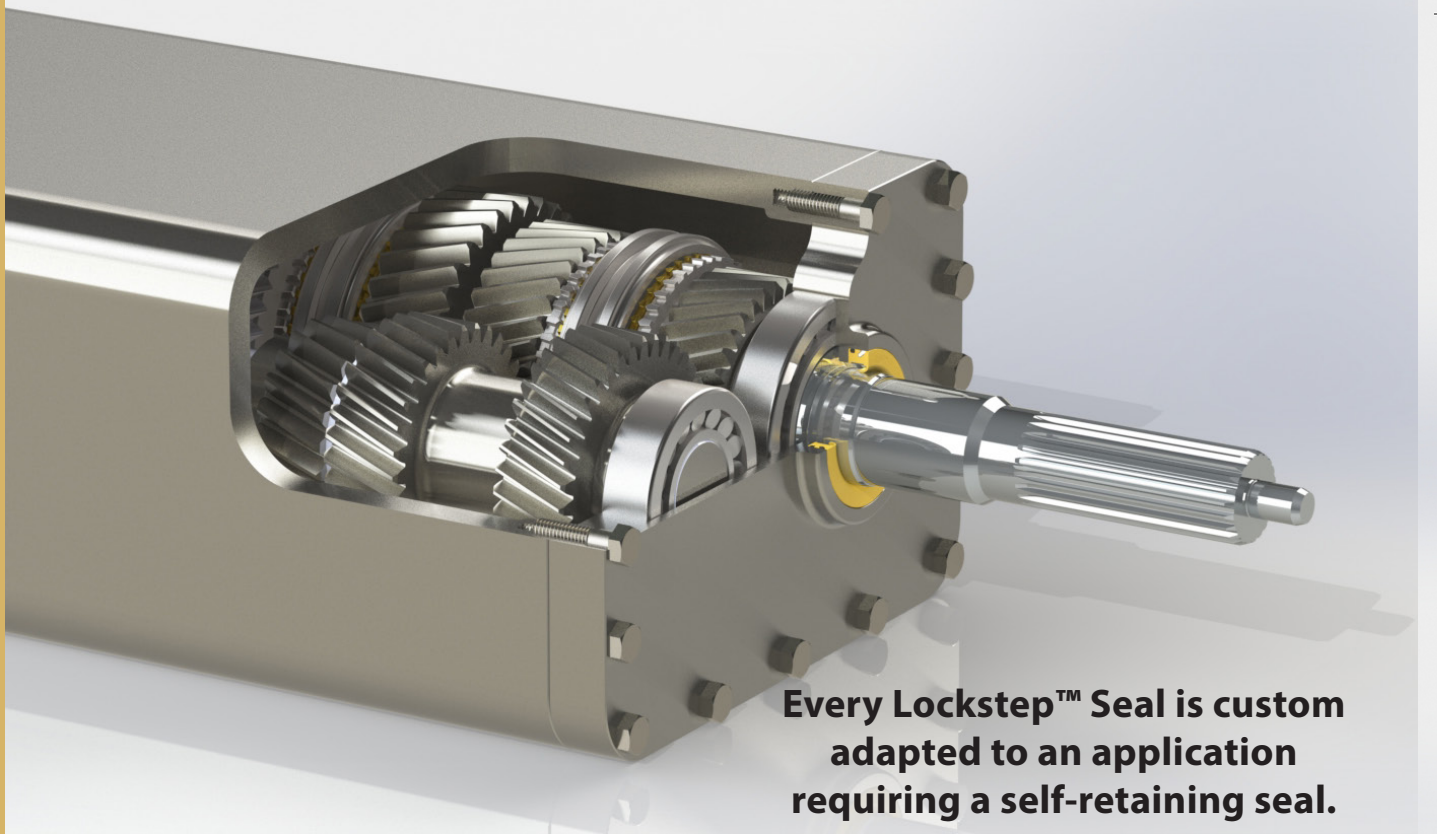

Every Lockstep™ Seal is custom adapted to an application requiring a self-retaining seal.

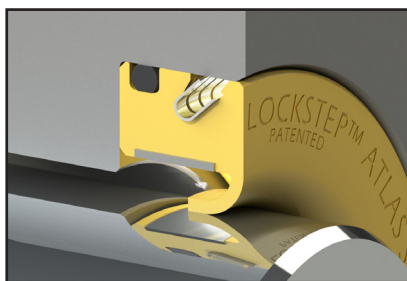

## STANDARD LOCKSTEP™

External open housing, internal seal

Simple external press-in design for retaining lubrication or process fluids inside equipment.

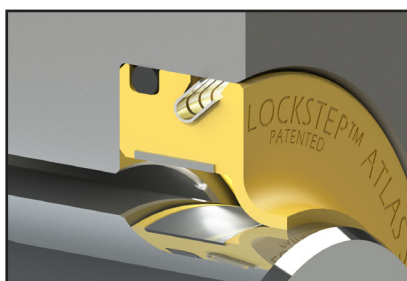

## HYGIENIC LOCKSTEP™

External excluder in open housing

For food and beverage or medical equipment where cleanliness is important with frequent wash-down requirements. We design solutions without open cavities to trap contaminants, and may also utilize a silicone fill for certain designs.

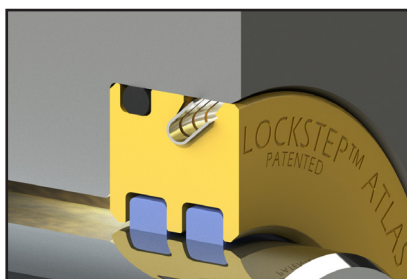

## LABYRINTH LOCKSTEP™

Bearing isolators or efficiency seals

Non-contacting or semi-contacting seal types can also be retained using the Lockstep™. Typically used in very high rotational speeds.

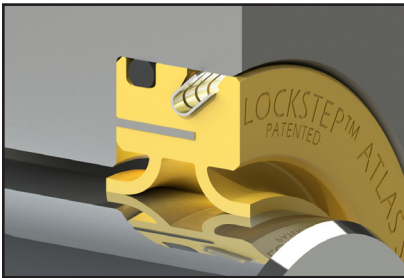
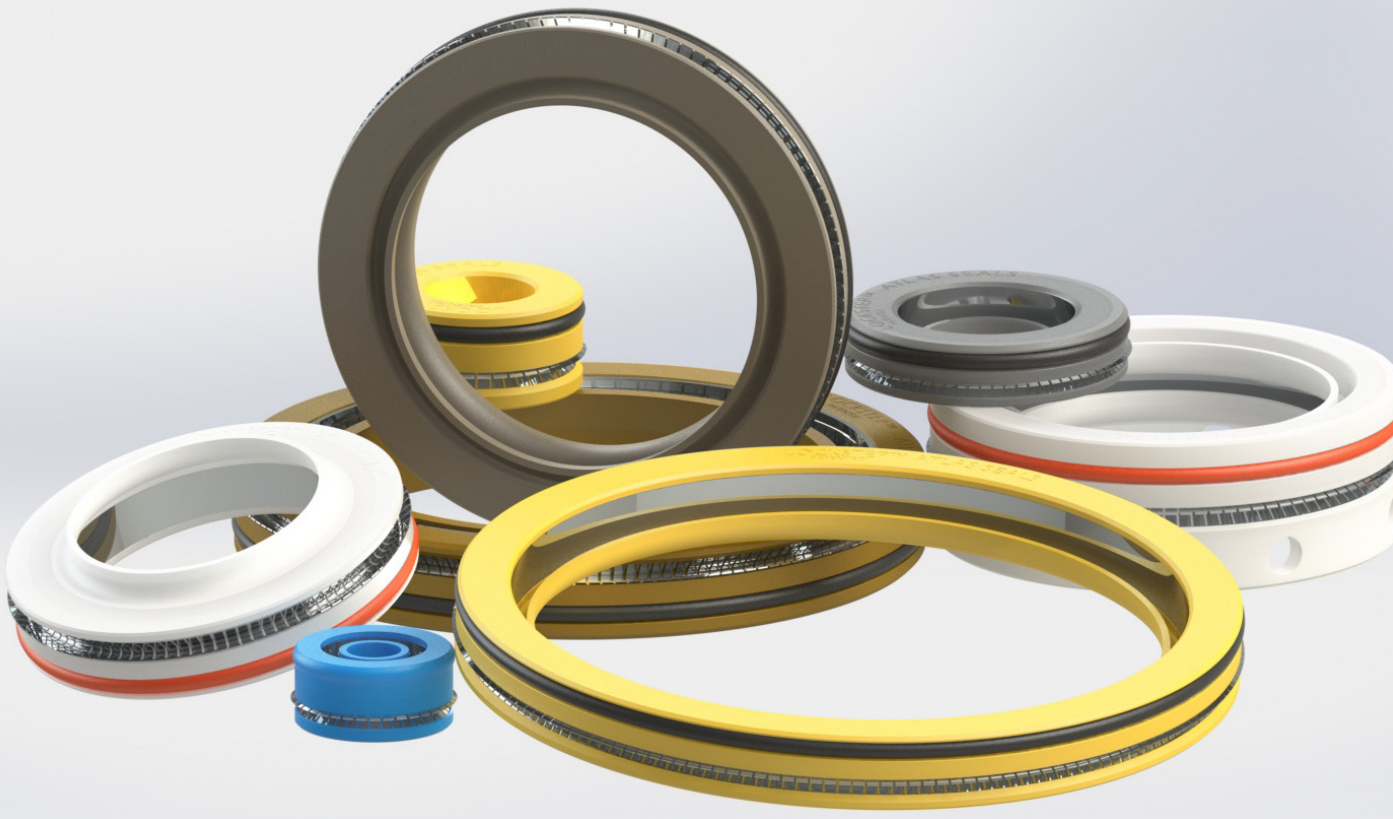

## BI-DIRECTIONAL LOCKSTEP™

Retain fluids and exclude contaminants

Multiple lips can be configured to assure separation of lubrication or process fluids from environmental factors and contaminants.

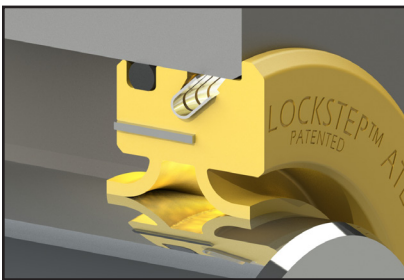

## THRU-BORE LOCKSTEP™

Simplified housings

The Lockstep™ can be utilized to eliminate difficult machining operations and even reduce the number of parts in an assembly.



## SPRING LOADED LIP LOCKSTEP™

Heavy duty applications

A wide variety of springs can be incorporated to increase the sealing lips contact force and response to motion.

**LOCKSTEP™ IN PTFE**  
**ATLAS HAS MORE THAN 30 PTFE**  
**COMPOUNDS TO SUIT ANY APPLICATION.**

# TOUGH ENVIRONMENT TESTED

## WHY PTFE?

PTFE is a high performance semi-rigid engineering thermoplastic capable of handling application criteria impossible for typical elastomer seal materials

- Chemical compatibility with the widest range of media and environmental exposures
- High surface speeds beyond the capabilities of rubber seals.
- Temperature range widest of all flexible seal materials: **-330 to 550°F / -200 to 260°C**
- Lowest friction (*energy*)
- Dry running without damage

PTFE is lathe turned from tube stock, eliminating the need for mold tooling and affording a high degree of customization to the specific needs of tough seal applications.

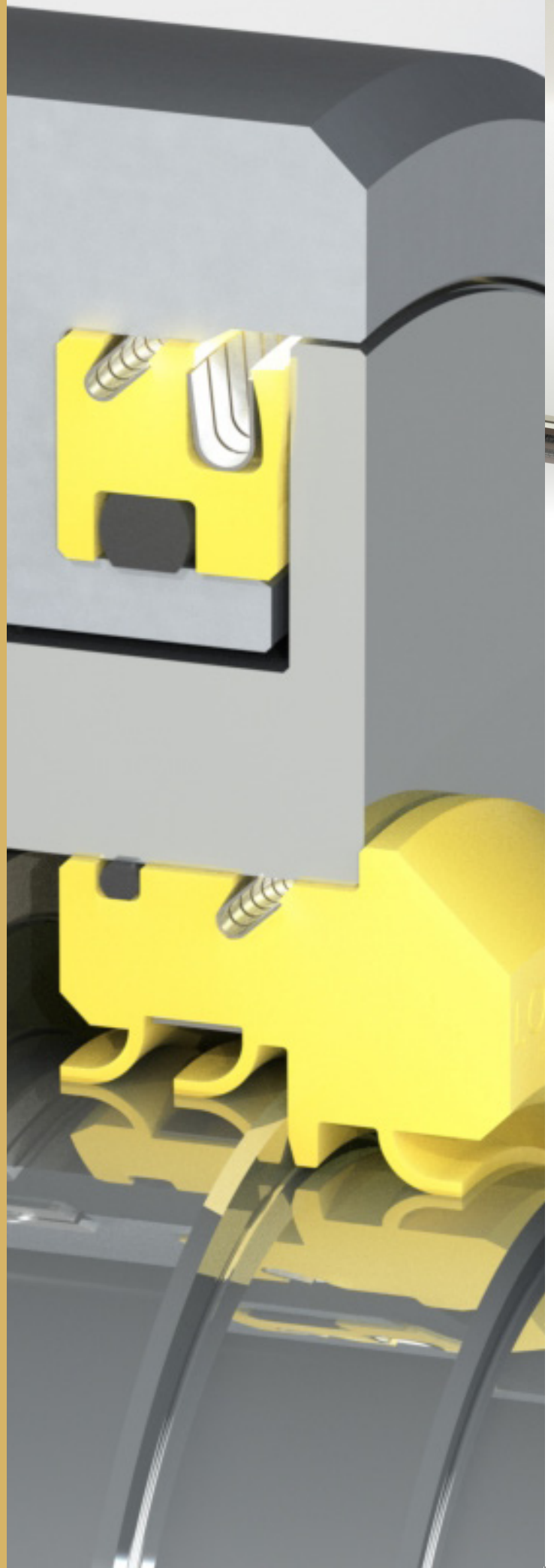

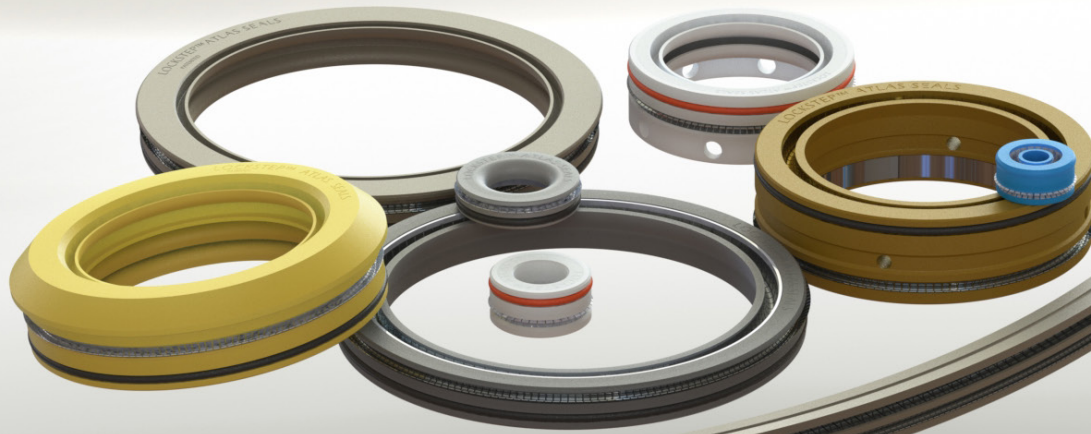

**Atlas Lockstep™ PTFE Rotary Seal similarities and advantages vs typical metal-cased PTFE Rotary seal**

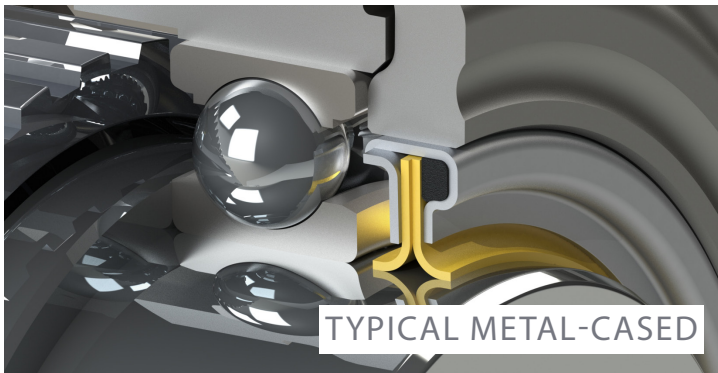

**TYPICAL METAL-CASED PTFE ROTARY SEAL**

- Press fit with metal can
- High tooling cost and long lead time
- Low volumes very expensive

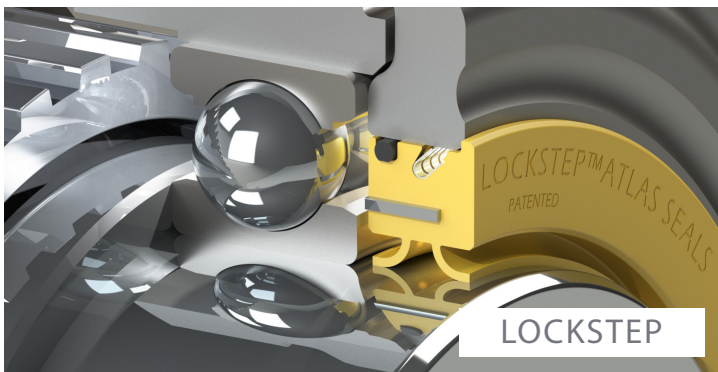

**ATLAS LOCKSTEP™ PTFE ROTARY SEAL**

- Rapid prototypes
- No tooling
- Ease of install
- Lowest cost in low volume orders
- More robust sealing to housing (o-ring)
- Can hold **moderate** pressure\*

**SAME SEALING PRINCIPLES:**

Lip style, lip material, and lip geometry and dimensions

\* Design and applications specific. Contact Atlas Seals Engineering

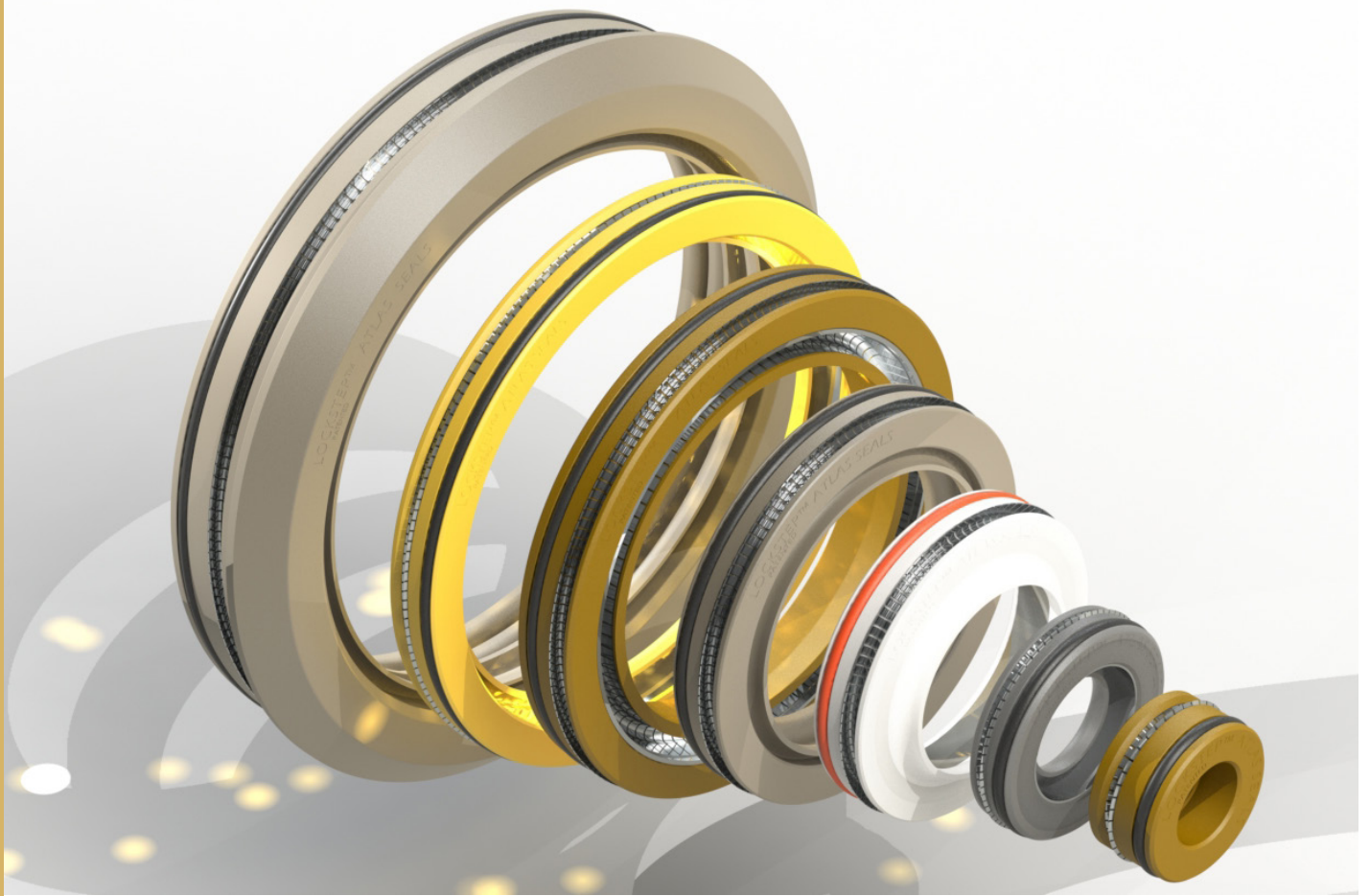

**Every Lockstep™ Seal is custom engineered. The pressure velocity limit depends on many applications and design factors.**

Depending on the application, we can design rotary seals in excess of 5000 PSI (350 bar). Contact Atlas Seals engineering.

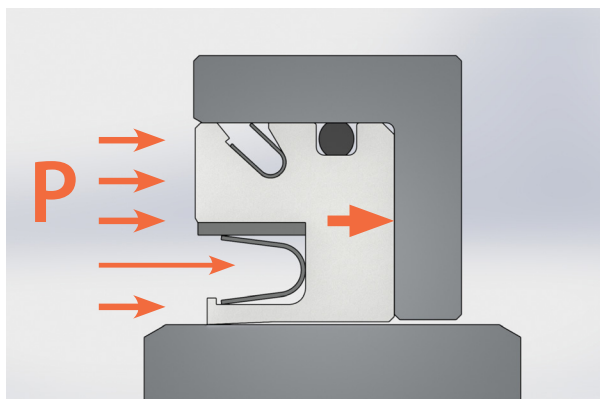

Pressure forcing seal into the groove or against other hardware.

Pressure limit depends on specific seal design.

The chart on the opposing page is an example guide.

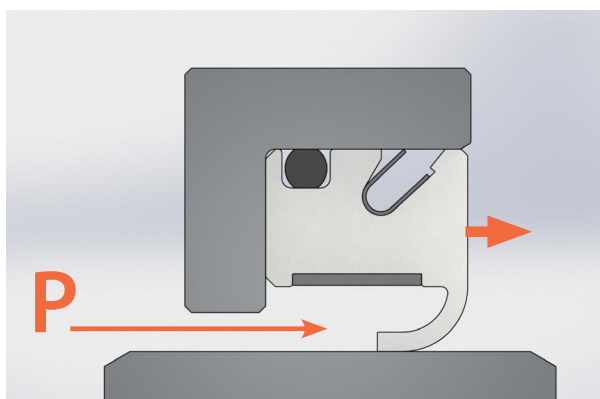

Pressure forcing seal out of groove, contained by Lockstep™ Locking barb.

Contact Atlas Seal Engineering if pressure is in excess of 15 PSI (1 bar).

Limits depend on size and style. Atlas has successfully retained in excess of 100 PSI (7 bar) with the locking barb alone.



# RECOMMENDED PRESSURE VELOCITY (PV) LIMIT

Surface Velocity = the sliding speed between the rotating surface and the seal.  
Higher pressures reduce the recommended limit.

PTFE seals have general recommended limits of pressure\* velocity (PV):

150,000 PV in PSI\*FT/MIN

This limit depends on seal design, material, all application criteria, and is generally applicable under 350°F / 175°C.

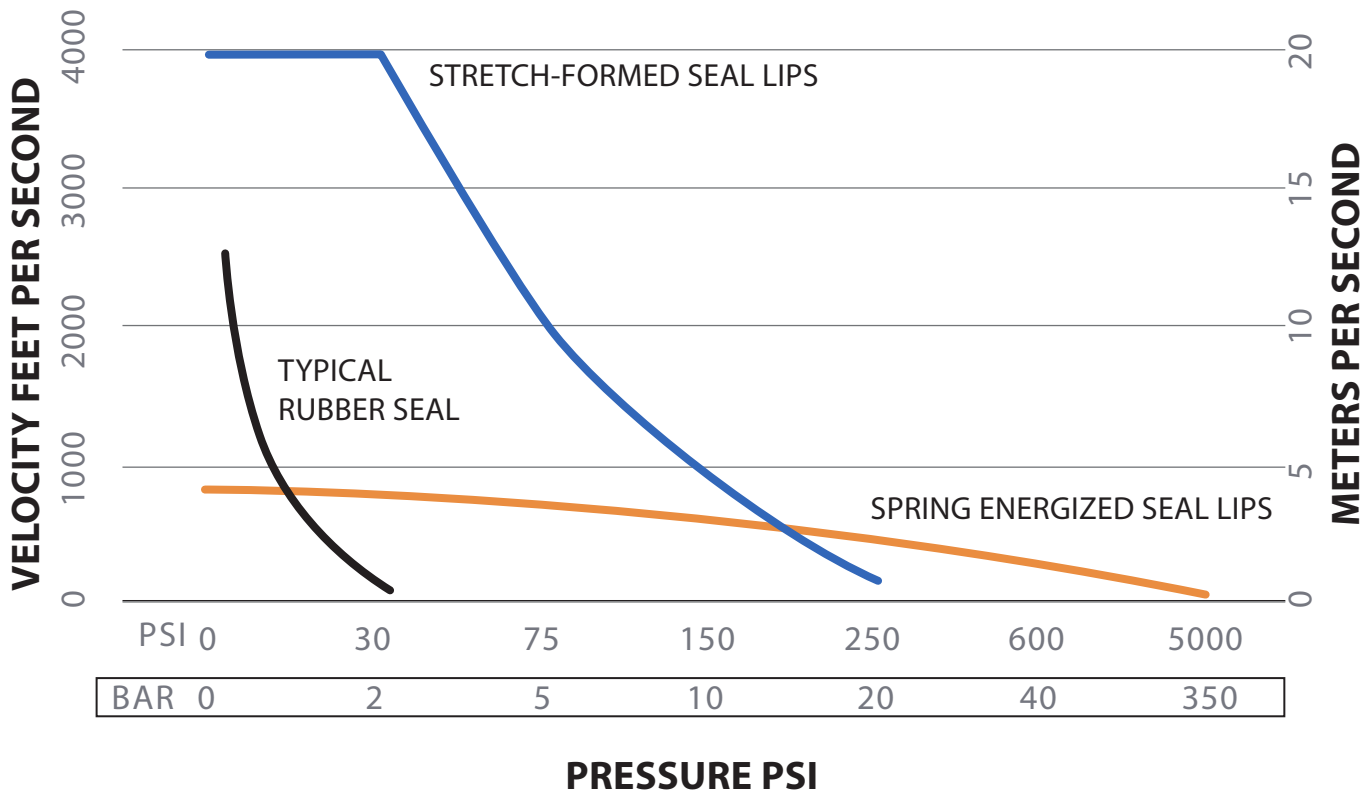

\* Contact Atlas Seals engineering for support with applications exceeding these levels.

STRETCH-FORMED SEAL LIPS



SPRING ENERGIZED SEAL LIPS

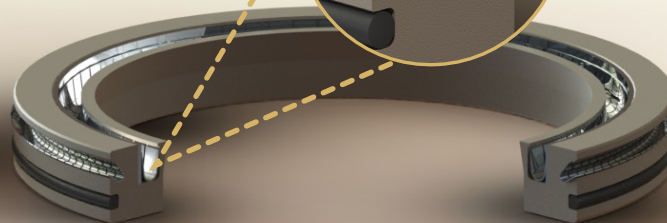
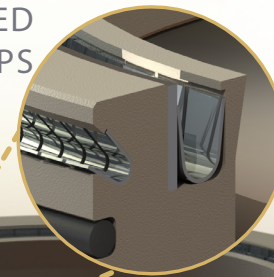

PRESSURE AND VELOCITY CAPABILITIES



THE PINNACLE OF  
SEALING PERFORMANCE

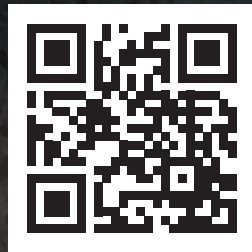

[www.atlasseals.com](http://www.atlasseals.com)

257 West 2950 South  
Salt Lake City, Utah 84115

**Phone:** 801-466-4174

**Fax:** 801-467-4750

©Atlas Seals, Inc. 2020